

HALLOWELL® 400/800 SERIES CABINET

Assembly Instructions / Parts Manual

PLEASE READ INSTRUCTIONS CAREFULLY BEFORE BEGINNING CABINET ASSEMBLY.
Retain instructions for future reference.

Description

Hallowell storage, wardrobe and combination cabinets are designed to provide secure store for office supplies, books, tools, office machines, etc. in offices, schools, institutions business and industrial store rooms.

The cabinet handle is supplied with built-in lock and two keys. The 3-point locking system has locks bars located in nylon guides for quiet operation.

Model 415/425/815/825: Storage Cabinet with 4 adjustable shelves

Model 435/445/835/845: Wardrobe Cabinet with one hat shelf and a full width coat rod

Model 455/465/855/865: Combination Cabinet with one hat shelf, center partition, 3 half width adjustable shelves and half width coat rod

Overall Dimensions

Models 415, 435, 455 are 72" high by 36" wide by 18" or 24" deep

Models 425, 445, 465 are 72" high by 48" wide by 18" or 24" deep

Models 815, 835, 855 are 78" high by 36" wide by 18" or 24" deep

Models 825, 845, 865 are 78" high by 48" wide by 18" or 24" deep

General

- 1. Check material received against the packing list. First, check the number of packages received and then check the contents of each package.**
- 2. Check the material received for damage. If damage occurred, secure a "damage notation" from the carrier.**
- 3. Identify each part as it is unpacked and put like parts together as soon as possible to the working area where they are to be assembled.**
- 4. Be careful to use the correct hardware as specified in assembly.**



Info@Hallowell-List.com

www.Hallowell-List.com

866-566-0500

Assembly Instructions (All Models)

**Tools Required: 3/8" nut driver, slotted screwdriver, rubber mallet.
Do NOT fully tighten bolts until cabinet is completely assembled.**

- 1. Place rear panel (item 5) on either padded horses or on protected floor with flanges upward.**
- 2. Attach side panels (items 7) with the flange under the rear panel offset with 10-24x3/8" bolts and nuts. The bottom support strips should be at the same end and shelf adjustment strips pointed in the same direction.**
- 3. Place a shelf (item 8) into shelf adjustment strips to hold sides in upright position while attach top (item 6).**
- 4. Place door frame assembly (items 1, 2, 3) on top of assembly and bolt to top and side panels.**
- 5. Position bottom (item 4) into offset support strips on sides and rear. Front flange of bottom must fit over front flange of frame and be bolted with 2 bolts for the outside (tighten).**
- 6. If model 455/465/855/865, install center divider (item 11 fig. 3) tighten bolt to bottom.**
- 7. Bolt (4) cabinet foot plates (items 13) to frame and sides and rear (tighten). All models. Skip this step for mobile cabinets.**
- 8. Stand cabinet upright, be sure cabinet is level and doors close properly and then tighten all bolts.**
- 9. Insert one side of adjustable shelf (item 8 or 12) at desired position then move other side up to the same position. If model 435/445/835/845, bolt one coat rod holder (item 10B) inside the flange of shelf with bolt heads outward. Slide rod (item 9 or 10A) into place, place second rod holder on opposite end of rod and then bolt second rod holder to shelf. Insert in top location. Seat all shelves with mallet.**
- 10. Using rubber mallet, tap nylon rod guide (item 15) into top and bottom flanges of right door (item 2).**
- 11. Install turn handle (item 14) to right door with #8-32 bolts (item 19) through handle plate (item 21) – reference door handle detail. Place lock cam (item 17) on back of handle with pins out. Insert lock rods (item 16) into rod guides and position holes in lock rods on pins of lock cam. Secure in place with cam keeper (item 18) using hitch pin clip (item 20).**
- 12. For mobile cabinets only, attach two casters to each of two caster plates and then attach caster plates to cabinet bottom (see Caster Kit detail).**

Hallowell® 400 Series Cabinet Components

Item	Description	Model 415/425		Model 435/445		Model 455/465	
		Qty	Part #	Qty	Part #	Qty	Part #
	Door & Frame Assembly	1	ICDFww72Pss	1	ICDFww72Pss	1	ICDFww72Pss
1	Left Door †	1	ICRDww72-22Pss	1	ICRDww72-22Pss	1	ICRDww72-22Pss
2	Right Door †	1	ICLDww72-22Pss	1	ICLDww72-22Pss	1	ICLDww72-22Pss
3	Door Frame †	1	ICFATww72P	1	ICFATww72P	1	ICFATww72P
4	Bottom	1	ICBwwdd-22	1	ICBwwdd-22	1	ICBwwdd-22
5	Rear Panel	1	ICRww72-22F	1	ICRww72-22F	1	ICRww72-22F
6	Top	1	ICTwwdd-22	1	ICTwwdd-22	1	ICTwwdd-22
7	Side Panel	2	ICSdd72-22F	2	ICSdd72-22F	2	ICSdd72-22F
8	Full Width Shelf	4	ICASwwdd	1	ICASwwdd	1	ICASwwdd
9	Full Width Coat Rod			1	KCRww		
10A	Half Width Coat Rod					1	KCRxx
10B	Rod Holder			2	TRH400		
11	Center Divider					1	ICDdd72
12	Half Width Shelf					3	ICASxxdd
13	Cabinet Foot Plate	4	CFP100	4	CFP100	4	CFP100
14	Turn Handle Assembly	1	CH100A	1	CH100A	1	CH100A
15	Rod Guide	2	LRG1	2	LRG1	2	LRG1
16	Lock Rod	2	ICLR72T	2	ICLR72T	2	ICLR72T
17	Lock Cam ††	1		1		1	
18	Cam Keeper ††	1		1		1	
19	8-32 Round Head Bolt ††	2		2		2	
20	Hitch Pin Clip ††	1		1		1	
21	Turn Handle Plate ††	1		1		1	
22	Assembly Hardware	1	AH800CAB	1	AH800CAB	1	AH800CAB
	10-24 x 3/8 Bolt *	80	MBT200	80	MBT200	80	MBT200
	10-24 Nut *	80	N201	80	N201	80	N201

Notes:	Legend
† Note that doors (items 1 and 2) are prehung in frame (item 3) at factory. †† Included with turn handle (item 14). * Included in assembly Hardware.	ww = Width xx = 1/2 of width dd = Depth ss = Door Type Suffix <ul style="list-style-type: none"> • Blank for solid door • -SV for Safety-View • -EV for ventilated



Info@Hallowell-List.com
 www.Hallowell-List.com
 866-566-0500

Hallowell® 800 Series Cabinet Components

Item	Description	Model 815/825		Model 835/845		Model 855/865	
		Qty	Part #	Qty	Part #	Qty	Part #
	Door & Frame Assembly	1	ICDFww78Pss	1	ICDFww78Pss	1	ICDFww78Pss
1	Left Door †	1	ICRDww78Pss	1	ICRDww78Pss	1	ICRDww78Pss
2	Right Door †	1	ICLDww78Pss	1	ICLDww78Pss	1	ICLDww78Pss
3	Door Frame †	1	ICFATww78P	1	ICFATww78P	1	ICFATww78P
4	Bottom	1	ICBwwdd	1	ICBwwdd	1	ICBwwdd
5	Rear Panel	1	ICRww78F	1	ICRww78F	1	ICRww78F
6	Top	1	ICTwwdd	1	ICTwwdd	1	ICTwwdd
7	Side Panel	2	ICSdd78F	2	ICSdd78F	2	ICSdd78F
8	Full Width Shelf	4	ICASwwdd	1	ICASwwdd	1	ICASwwdd
9	Full Width Coat Rod			1	KCRww		
10A	Half Width Coat Rod					1	KCRxx
10B	Rod Holder			2	TRH400		
11	Center Divider					1	ICDdd78
12	Half Width Shelf					3	ICASxxdd
13	Cabinet Foot Plate	4	CFP100	4	CFP100	4	CFP100
14	Turn Handle Assembly	1	CH100A	1	CH100A	1	CH100A
15	Rod Guide	2	LRG1	2	LRG1	2	LRG1
16	Lock Rod	2	ICLR78T	2	ICLR78T	2	ICLR78T
17	Lock Cam ††	1		1		1	
18	Cam Keeper ††	1		1		1	
19	8-32 Round Head Bolt ††	2		2		2	
20	Hitch Pin Clip ††	1		1		1	
21	Turn Handle Plate ††	1		1		1	
22	Assembly Hardware	1	AH800CAB	1	AH800CAB	1	AH800CAB
	10-24 x 3/8 Bolt *	80	MBT200	80	MBT200	80	MBT200
	10-24 Nut *	80	N201	80	N201	80	N201

Notes:	Legend
† Note that doors (items 1 and 2) are prehung in frame (item 3) at factory.	ww = Width
†† Included with turn handle (item 14).	xx = 1/2 of width
* Included in assembly Hardware.	dd = Depth
	ss = Door Type Suffix
	• Blank for solid door
	• -SV for Safety-View
	• -EV for ventilated



Info@Hallowell-List.com
 www.Hallowell-List.com
 866-566-0500

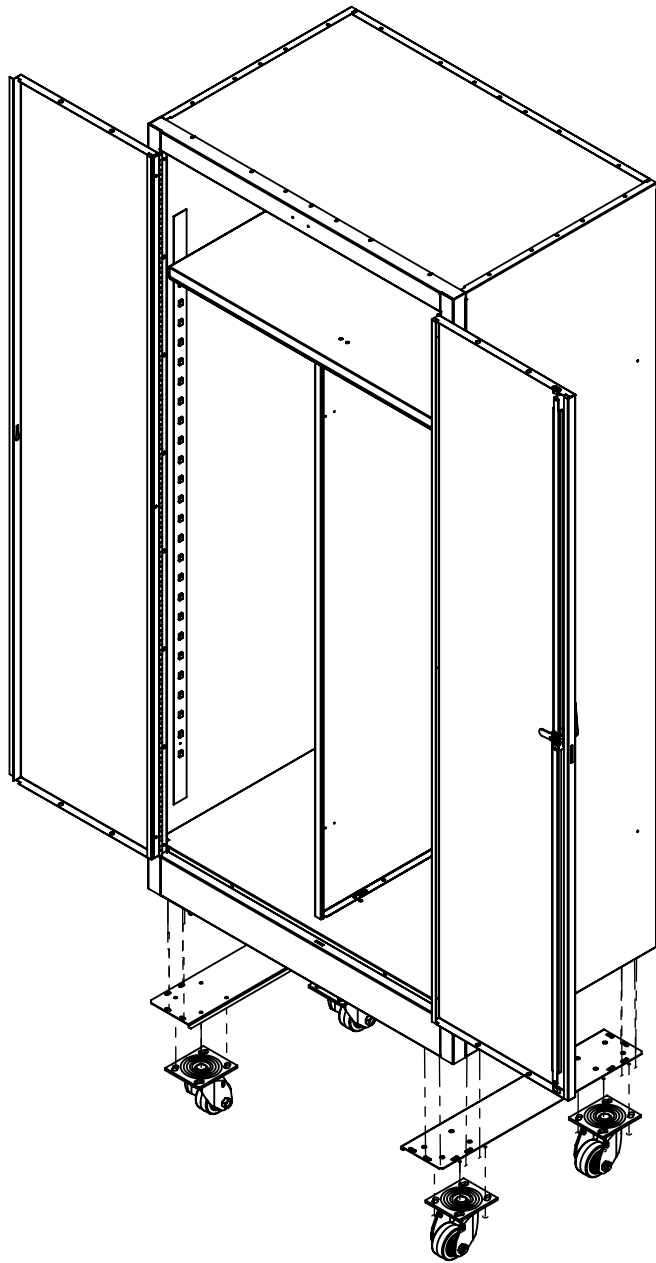

CASTER KIT

14 GA. C.R.S.

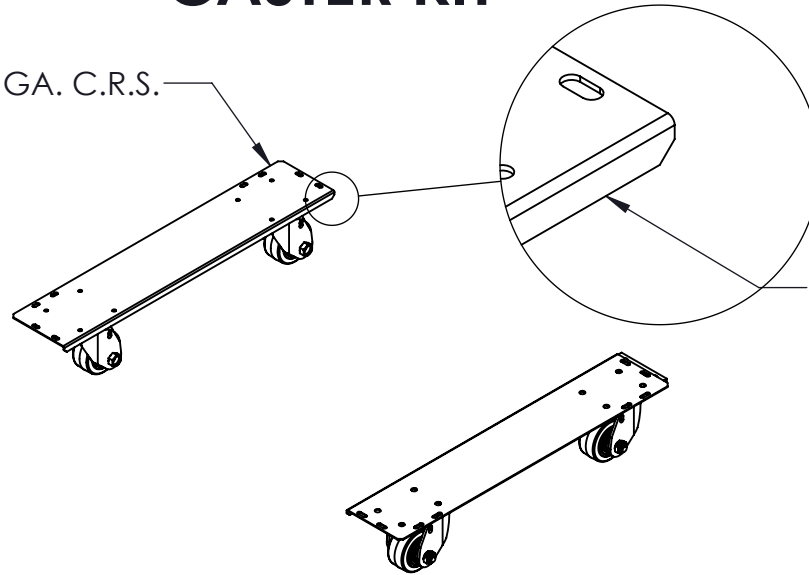

REINFORCING .5" RIB

USE TO BOLT CASTER KIT TO CABINET.



MBT200



N201

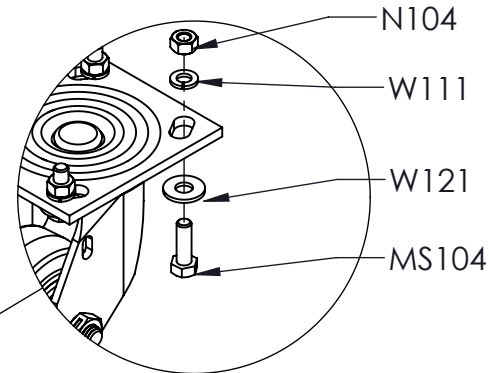

BOLT ASSEMBLY

THIS DRAWING AND THE INFORMATION ON IT IS THE CONFIDENTIAL PROPERTY OF HALLOWELL. AND SHALL NOT BE COPIED OR DISCLOSED TO OTHERS WITHOUT WRITTEN PERMISSION. ONLY HALLOWELL RESERVES THE RIGHT TO ALTER ANY DESIGN. ANY UNAUTHORIZED MODIFICATIONS RELEASES HALLOWELL FROM ALL LIABILITIES.

TOLERANCES UNLESS OTHERWISE SPECIFIED

INCHES
XX. ± .010
XXX. ± .005

FRACTIONAL
X/X. ± 1/64

ANGULAR
∠ ± 1/2°

UNLESS OTHERWISE SPECIFIED ALL DIMENSIONS ARE IN INCHES. METRIC DIMENSIONS WILL BE WITHIN [XX]

Hallowell

www.Hallowell-List.com

2823 W. ORANGE AVE.
APOPKA, FLORIDA 32703

Tel (866) 566-0500
Fax (407) 464-3610

DRAWN BY	DATE	DESCRIPTION
JIL	02/07/11	
CHECKED BY	DATE	

CASTER KIT ASSEMBLY

APPROVED BY	DATE	SCALE	SHEET	PART NO.	DRAWING NO.	REV.
RAM	9/27/16		1 OF 1	CC-24ME	SA1549	

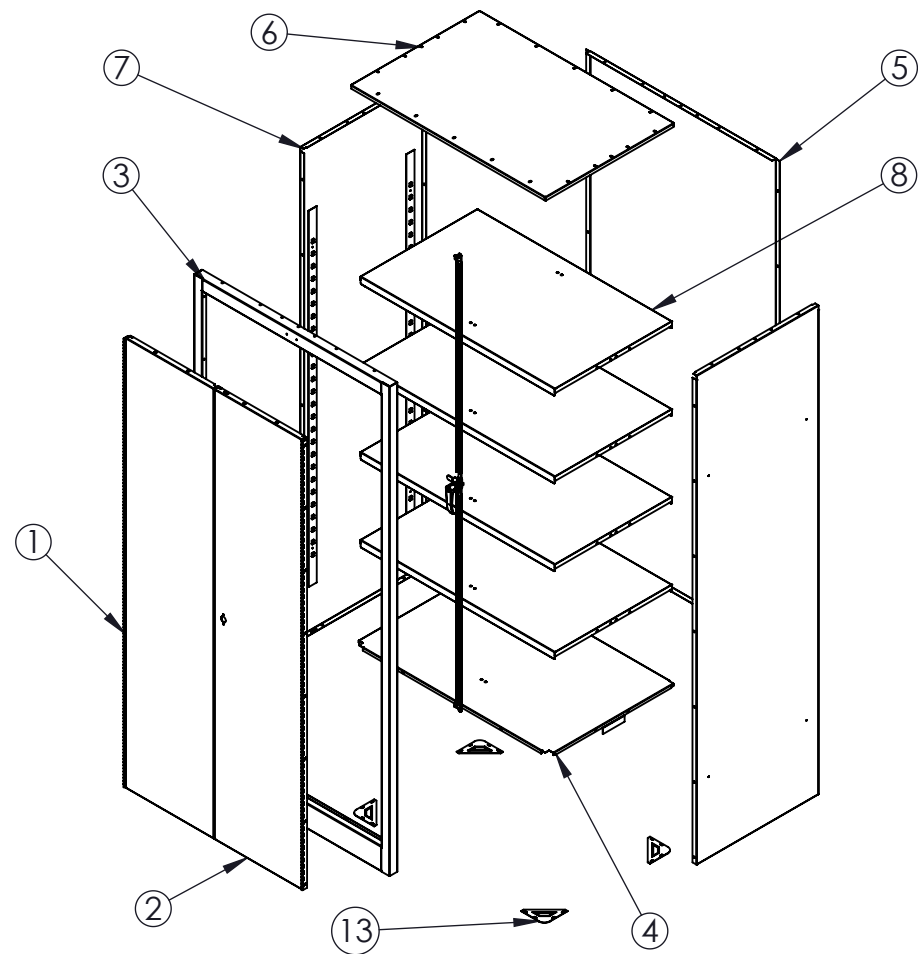

#815/825-#415/425 - STORAGE

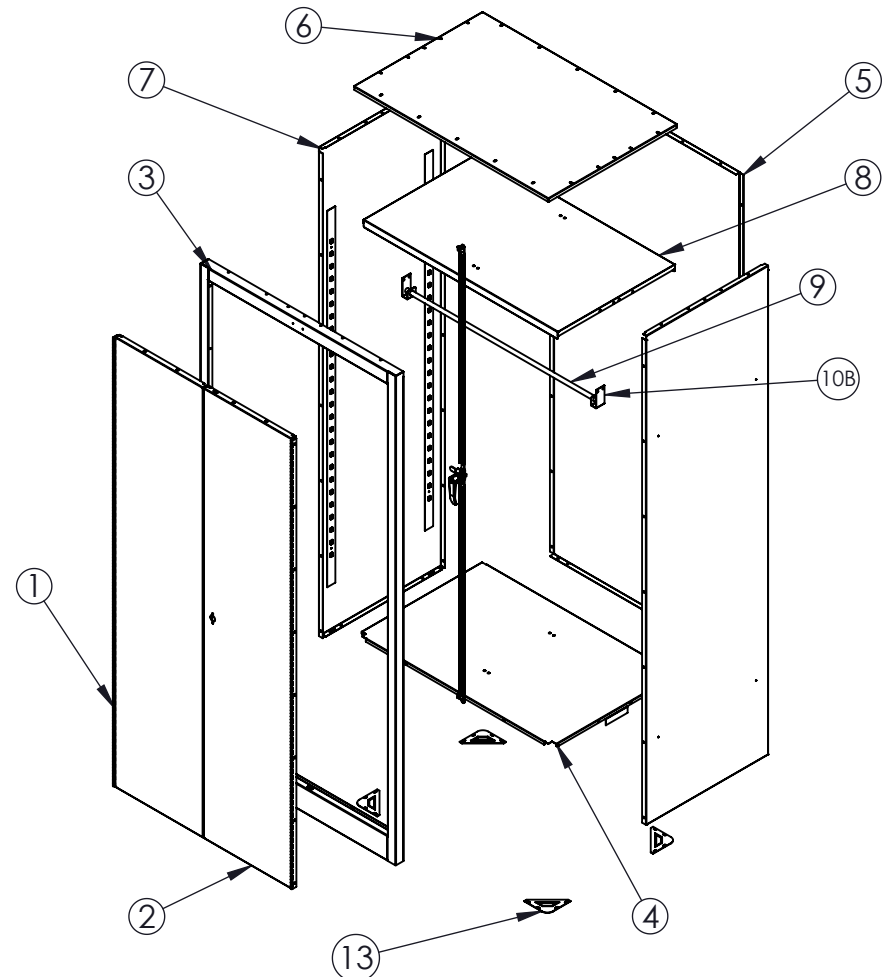

#835/845-#435/445 - WARDROBE

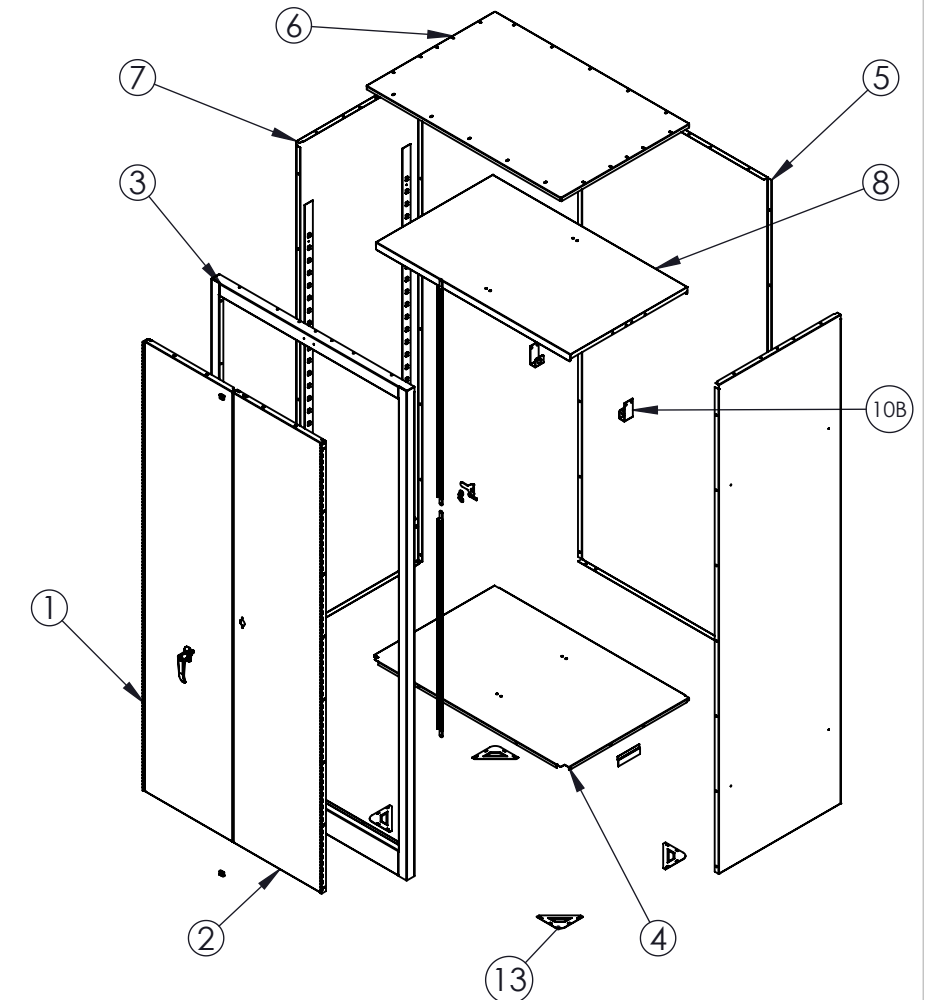

#855/865-#455/465 - COMBO

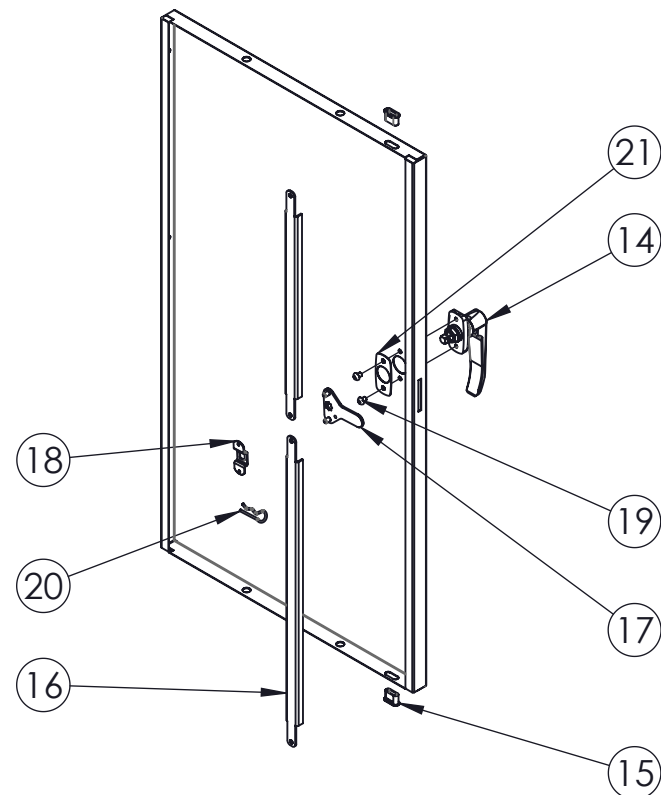

ITEM #	LEGEND
1	LEFT DOOR
2	RIGHT DOOR
3	FRAME
4	BOTTOM
5	REAR PANEL
6	TOP
7	SIDE PANEL
8	FULL WIDTH ADJUSTABLE SHELF
9	FULL WIDTH COAT ROD
10A	HALF WIDTH COAT ROD
10B	ROD HOLDER (2)
11	DIVIDER

ITEM #	LEGEND
12	HALF WIDTH ADJUSTABLE SHELF
13	CABINET FOOT PLATE
14	TURN HANDLE ASSEMBLY
15	ROD GUIDE
16	LOCK ROD
17	CAM
18	CAM KEEPER
19	BOLT (2)
20	HITCH PIN CLIP
21	TURN HANDLE PLATE

THIS DRAWING AND THE INFORMATION ON IT IS THE CONFIDENTIAL PROPERTY OF HALLOWELL, AND SHALL NOT BE COPIED OR DISCLOSED TO OTHERS WITHOUT WRITTEN PERMISSION. ONLY HALLOWELL RESERVES THE RIGHT TO ALTER ANY DESIGN. ANY UNAUTHORIZED MODIFICATIONS RELEASES HALLOWELL FROM ALL LIABILITIES.

TOLERANCES UNLESS OTHERWISE SPECIFIED		 www.Hallowell-List.com 2823 W. ORANGE AVE. APOPKA, FLORIDA 32703 Tel (866) 566-0500 Fax (407) 464-3610	
INCHES XX. ± .010 XXX. ± .005			
FRACTIONAL X/X. ± 1/64		DRAWN BY: JIL DATE: 12/19/2013 CHECKED BY: _____ DATE: _____	DESCRIPTION: INDUSTRIAL CABINET ASSEMBLY
ANGULAR ∠ ± 1/2°		APPROVED BY: RAM DATE: 9/27/16	SCALE: 1 OF 1 SHEET: 1 OF 1 PART NO.: SB0237 DRAWING NO.: SB0237 REV.: _____
UNLESS OTHERWISE SPECIFIED ALL DIMENSIONS ARE IN INCHES. METRIC DIMENSIONS WILL BE WITHIN [XX]			