

**MAXIMUM NUMBER OF LOCKER FRAMES TO BE ASSEMBLED IN A GROUP**

LOCKER WIDTH	9'	12'	15'	18'	24'
SINGLE ROW GROUP	6	6	5	4	3

**ASSEMBLY OF SINGLE ROW LOCKERS**

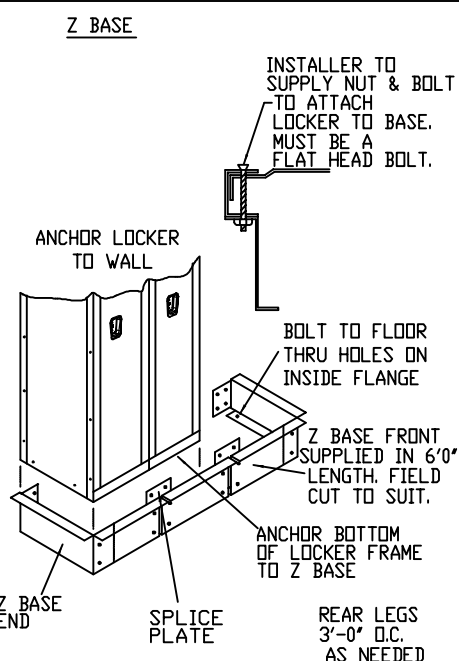
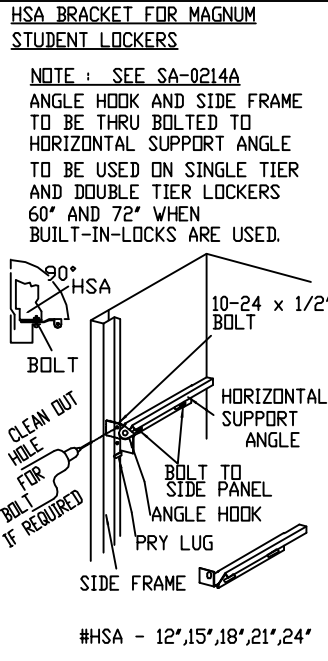
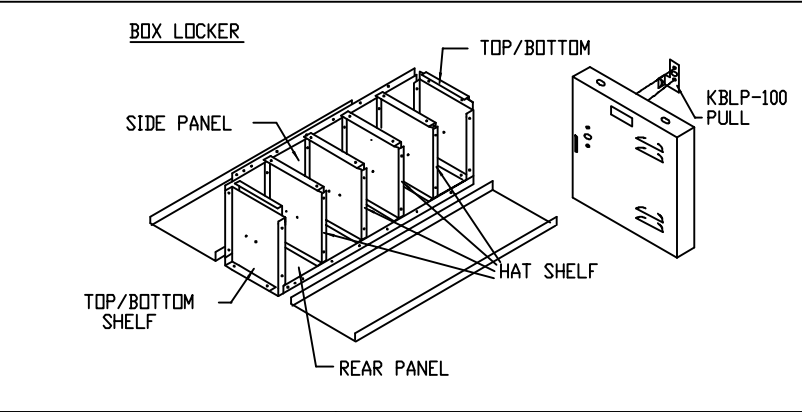
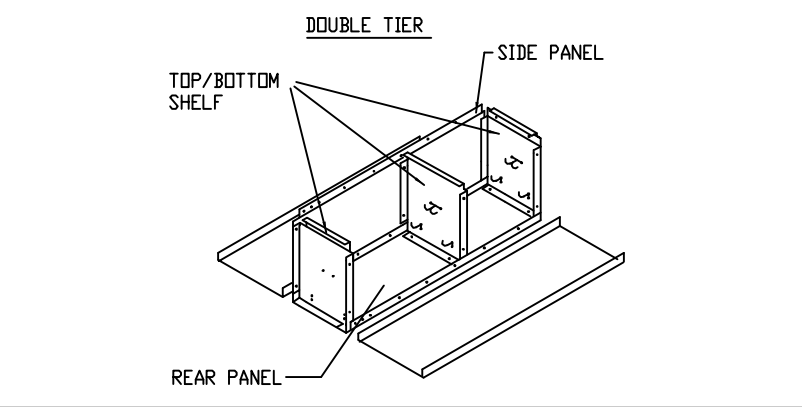
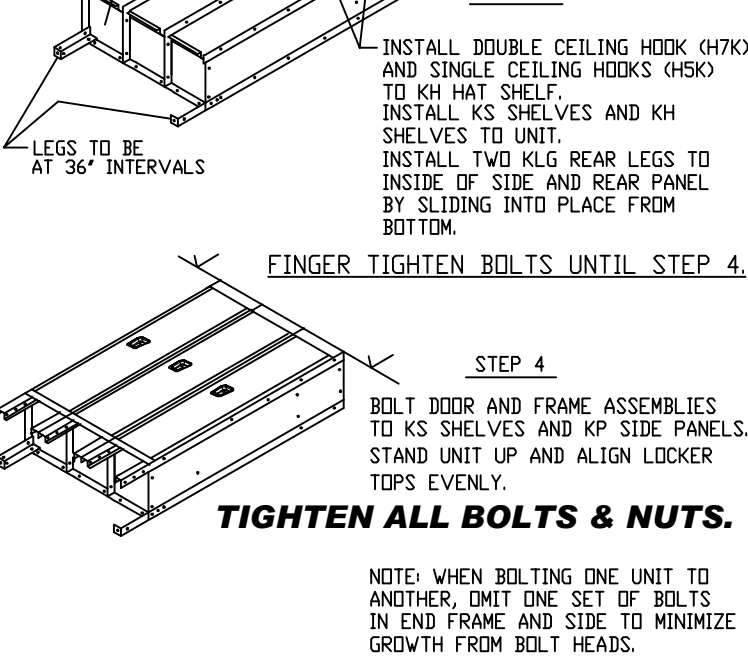
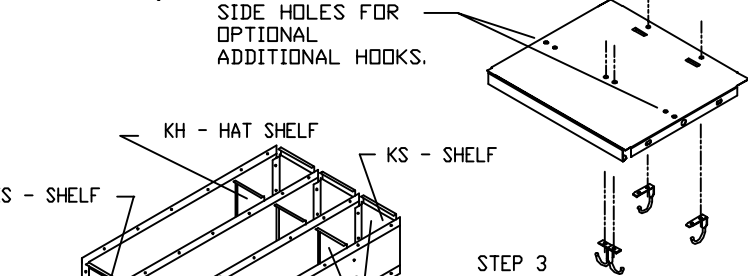
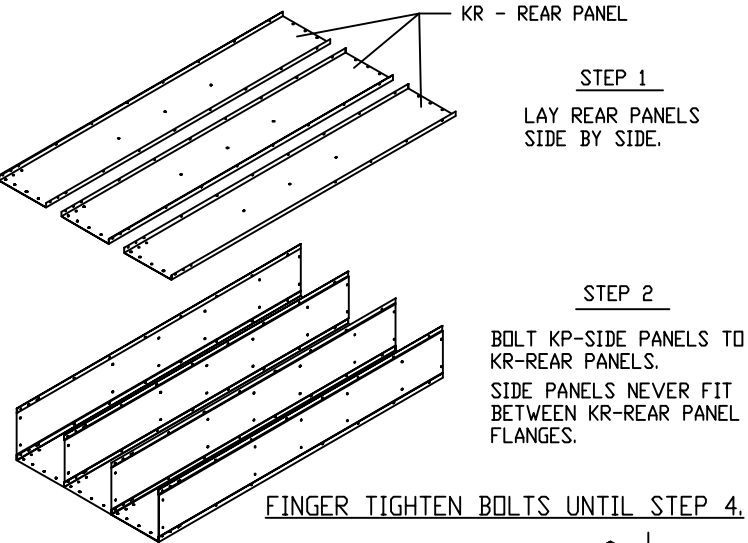
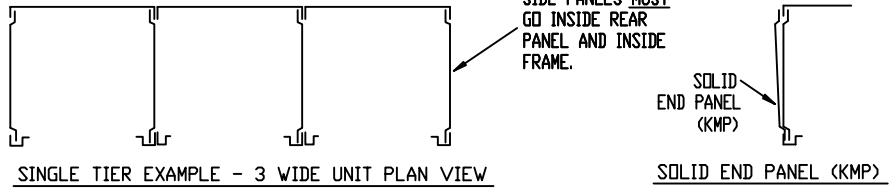

**K. D. LOCKER INSTALLATION DETAILS**

**CONTINUOUS SLOPED TOP**

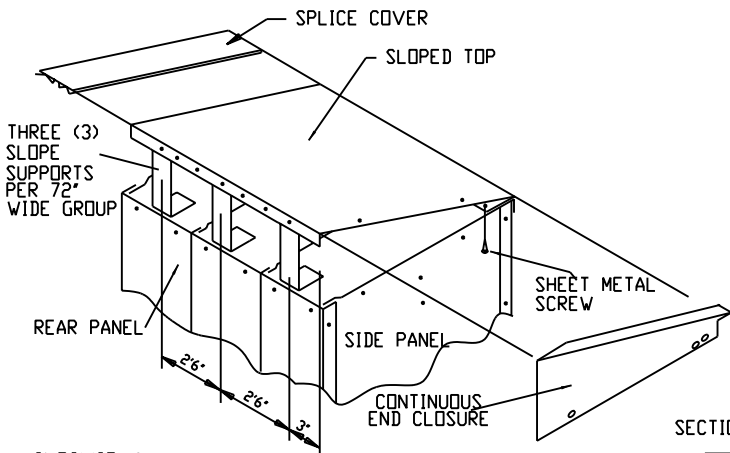

1. LEVEL AND BOLT LOCKERS TOGETHER BEFORE ATTEMPTING TO INSTALL SLOPED TOPS.
2. BOLT REAR FLANGE OF TOP TO (3) THREE SLOPE SUPPORTS AS SHOWN. (BACK TO BACK LOCKERS BOLT REAR FLANGE OF BOTH TOPS )
3. ATTACH END CLOSURE FOR CONCEALED CONDITION ONLY USING (2) TEK SCREWS THRU SLOPE TOP.
4. SLIP SPLICE COVER ONTO END(S) TO BE JOINED. PUT WHOLE ASSEMBLY ONTO TOP OF LOCKERS AND ALIGN.
5. DO THE SAME WITH THE NEXT SECTION OF SLOPED TOP AND SLIP INTO THE SPLICE COVER OF THE SECTION ALREADY FASTENED.
6. CUT LAST SECTION TO REQUIRED LENGTH AND SLIP CUT EDGE INTO THE LAST ATTACHED SPLICE COVER. THEN ATTACH SLOPE TOP TO END CLOSURE USING TEK SCREWS.
7. FASTEN THE FRONT FLANGE THROUGH THE HOLE IN THE FLAT TOP. (3) TEK SCREWS PER SLOPE TOP.
8. WHEN ALL FRONT FLANGES ARE FASTENED, ALIGN EXPOSED SLOPE END CLOSURES. FIRST FASTEN TO THE LOCKER, THEN DOWN THROUGH SLOPE TOP.

**INDIVIDUAL SLOPED TOP**

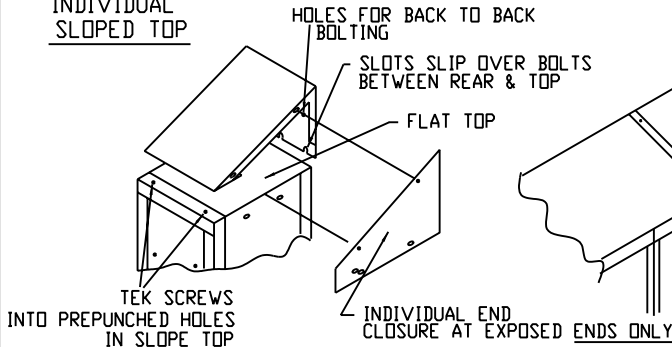

**SECTION THRU SPLICE COVER**

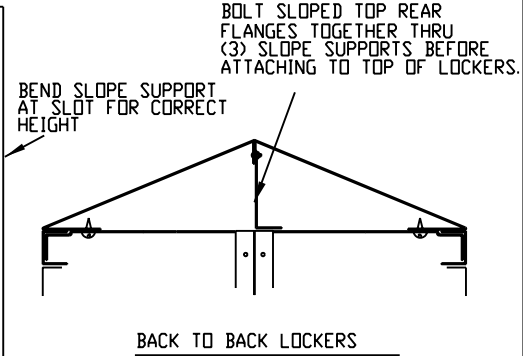
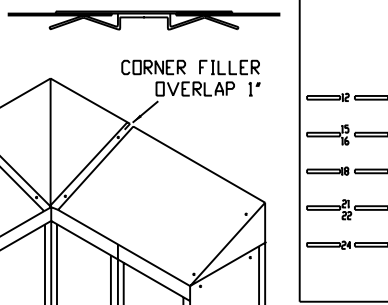

**BACK TO BACK LOCKERS**

**RECESS TRIM**

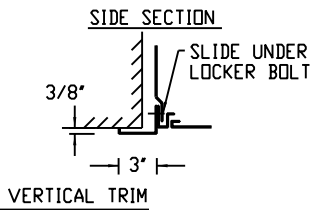

**VERTICAL TRIM**

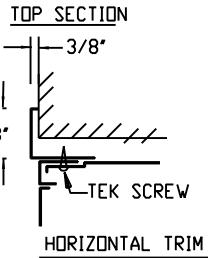

**HORIZONTAL TRIM**

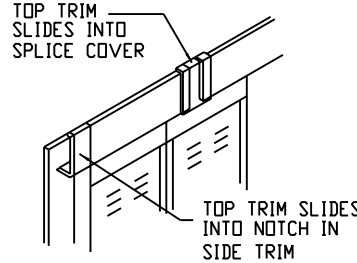

**SLIP JOINT**

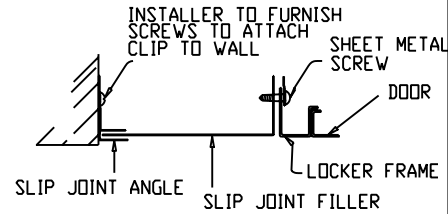

**RECOMMENDED TOOLS:**

- SABER SAW
- ELECTRIC 3/8" DRILL
- ELECTRIC SCREW GUN W/ ADJUSTABLE TORQUE
- #2 AND #3 PHILLIPS BITS
- 5/16", 3/8" AND 7/16" HEX DRIVES

- "C" CLAMPS
- VICE GRIPS
- ASSORTED CEDAR SHIMS
- 3/8" NUT DRIVER
- WONDER BAR
- RIVET GUN
- HAMMER DRILL

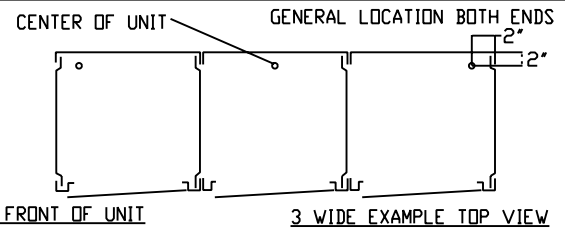
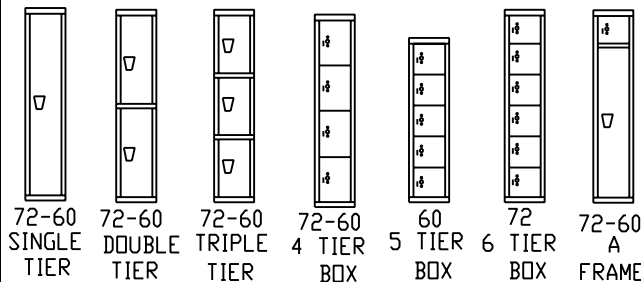
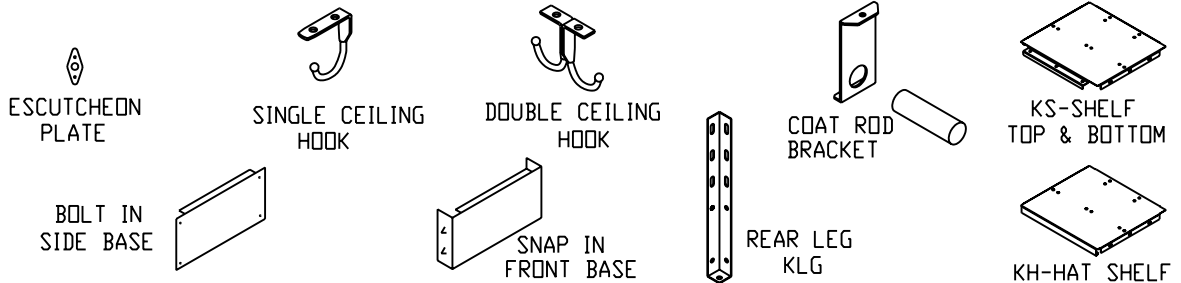

IN THE INTEREST OF SAFETY, ALL KD LOCKERS MUST BE SECURELY ANCHORED TO THE FLOOR AND WALL.



**K. D. LOCKER INSTALLATION DETAILS**