

SLOPE TOP CORNER

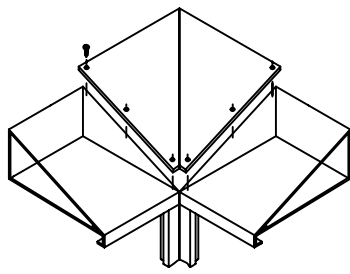

USE FILLER PLATE AS TEMPLATE, DRILL 1/8" DIAMETER HOLES INTO LOCKER UNIT AS SHOWN.
HARDWARE: (6) SHEET METAL SCREWS

SLOPED TOPS

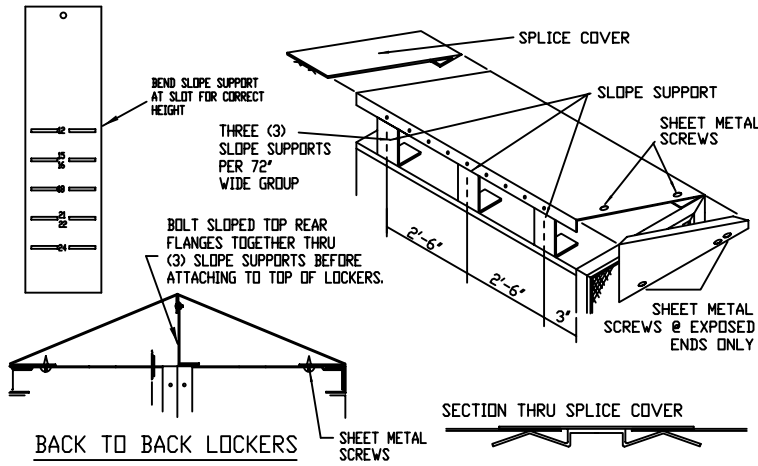

1. LEVEL AND BOLT LOCKERS TOGETHER BEFORE ATTEMPTING TO INSTALL SLOPED TOPS.
2. BOLT REAR FLANGE OF TOP TO (3) SLOPE SUPPORTS AS SHOWN (FOR BACK-TO-BACK LOCKERS BOLT THE REAR FLANGE OF BOTH TOPS TO SLOPE SUPPORTS).
3. ATTACH END CLOSURE FOR CONSEALED CONDITION ONLY USING (2) TEK SCREWS THRU SLOPE TOP.
4. SLIP SPLICE COVER ONTO THE ENDS TO BE JOINED. THEN PUT WHOLE ASSEMBLY ONTO THE TOP OF THE LOCKERS & ALIGN.
5. DO THE SAME WITH THE NEXT SECTION OF SLOPE TOP AND SLIP INTO THE SPLICE COVER OF THE SECTION ALREADY FASTENED.
6. CUT LAST SECTION TO REQUIRED LENGTH AND SLIP CUT EDGE INTO THE LAST ATTACHED SPLICE COVER. THEN ATTACH SLOPE TOP TO END CLOSURE USING TEK SCREWS.
7. FASTEN THE FRONT FLANGE THROUGH THE HOLE IN THE FLAT TOP. (3) TEK SCREWS PER SLOPE TOP.
8. WHEN ALL FRONT FLANGES ARE FASTENED, ALIGN EXPOSED SLOPE END CLOSURES. FIRST FASTEN TO THE LOCKER.

NOTE: DO NOT ATTACH FRONT FLANGES OF SLOPE TOPS TO LOCKER UNTIL ALL SLOPE TOPS ARE ALIGNED FOR AN ENTIRE RUN. ALL BOXED ENDS MUST BE ATTACHED PRIOR TO CONTINUOUS SLOPE TOPS.

FLAT TOP CORNER

USE FILLER PLATE AS TEMPLATE AND DRILL 1/8" DIAMETER HOLES INTO LOCKER UNIT AS SHOWN.

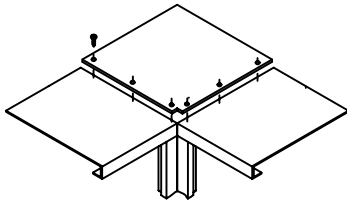

HARDWARE: PAN HEAD SHEET METAL SCREWS.

TOP FILLER

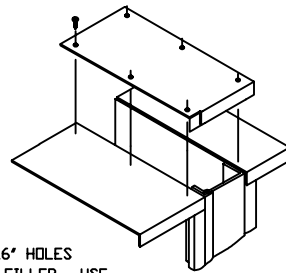

DRILL (6) 3/16" HOLES AS SHOWN IN FILLER, USE FILLER AS TEMPLATE AND DRILL (6) 1/8" HOLES IN LOCKER TOPS. ATTACH WITH SHEET METAL SCREWS.

NOTCH FRONT BEND OF FILLER AS REQUIRED TO PROVIDE CLEARANCE OF SLIP FILLER.

HARDWARE: PAN HEAD SHEET METAL SCREWS

UNIT TO BASE

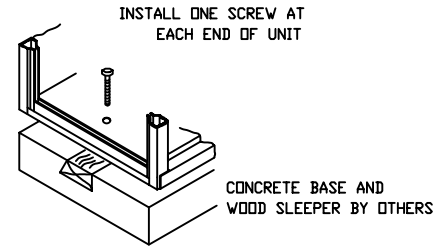

IMPORTANT: LOCKERS MUST BE LEVEL. USE CEDAR SHIMS IF NECESSARY TO PROVIDE FOR IRREGULARITIES IN BASE.

HARDWARE: (2) 1/4" X 4" HEX HEAD LAG SCREWS (SUPPLIED BY INSTALLER)

SOLID END PANEL

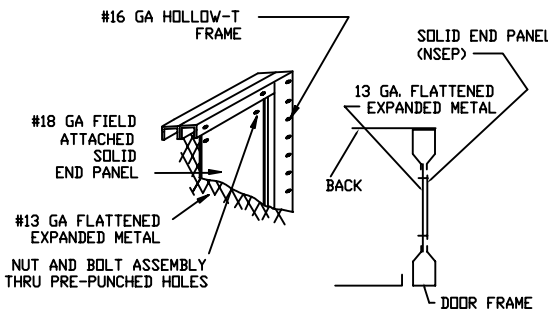

SOLID END PANEL FOR DEAD CORNERS AND FILLER CONDITIONS ONLY
NOTE: TO BE USED ONLY @ BLIND CONDITIONS

BOXED END PANEL

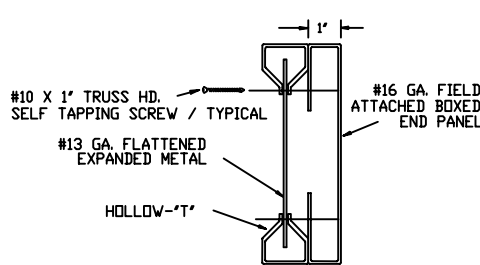

NOTE: TO BE USED ONLY @ EXPOSED ENDS

NUMBER AND STRIKE PLATES

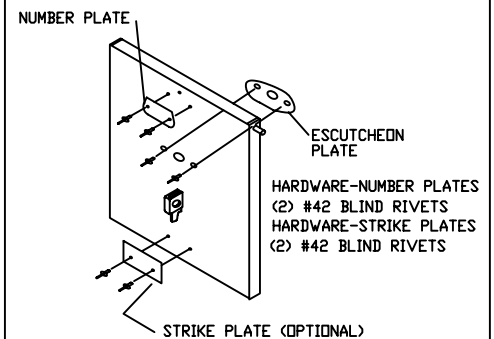

HARDWARE-NUMBER PLATES (2) #42 BLIND RIVETS
HARDWARE-STRIKE PLATES (2) #42 BLIND RIVETS

RECOMMENDED TOOLS

"C" CLAMPS, HAMMER DRILL, VICE GRIPS
SABER SAW, 3/8" ELECTRIC DRILL
3/8" NUT DRIVER, ASSORTED CEDAR SHIMS,
ELECTRIC SCREW GUN W/ADJUSTABLE TORQUE
WONDER BAR, #2 & #3 PHILLIPS BITS
RIVET GUN & 5/16, 3/8 AND 7/16" HEX DRIVES



401 Jim Moran Blvd., PO Box 9601, Deerfield Beach, FL 33442
Tel (954) 429-9155 Fax (954) 428-3843

REVISIONS

NO.	DATE	BY
1.	08-20-04	JMH
2.	-	-
3.	-	-
4.	-	-

INSTALLATION DETAILS FOR WELDED LOCKERS

DRWN BY	DATE	SCALE
JMH	01-19-04	NONE
CHK'D	DATE	DRWG NO.
-	-	SB-2301-1
APP'D	DATE	

POSITION LEGS AS SHOWN AT

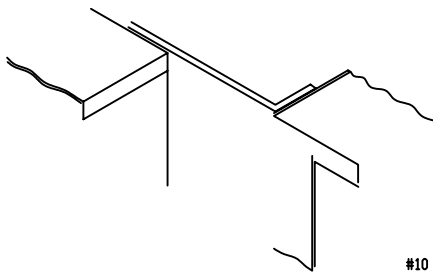

#10 FLAT HEAD SCREWS

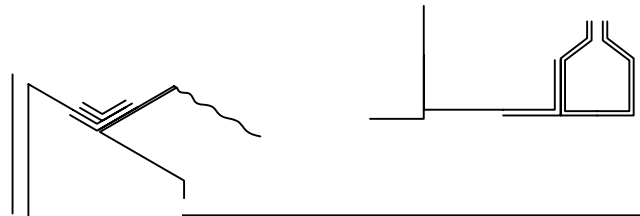

BACK TO BACK

UNITS END TO END

U

SHEET OF LOCKER AND INTO WALL APPROX. 2" FROM UPPER CORNER ON EACH SIDE OF UNIT.

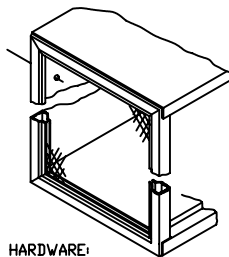

HARDWARE:
(2) ANCHORS BY INSTALLER-RECOMMENDED HILTI ALUMINUM HIT ANCHORS CAT. LNO. 5400192
1/4" X 2" TAP-CON OR QUICK.

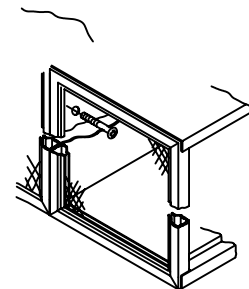

HARDWARE-SOLID BACK:
(2) 1/4" 20 X 3/4" PHILLIPS PAN HEAD MACHINE SCREWS
(2) 1/4" EXTERNAL TOOTH LOCK WASHERS
(2) 1/4"-20 HEX NUTS

HARDWARE-VENTILATED BACK:
(2) 1/4"-20 X 3/4" PHILLIPS PAN HEAD MACHINE SCREW
(4) 5/16" I.D. X 1-1/2" O.D. FENDER WASHER
(2) 1/4" EXTERNAL TOOTH LOCK WASHERS
(2) 1/4" X 20 HEX NUTS

"C" CLAMPS, HAMMER DRILL, VICE GRIPS
SABER SAW, 3/8" ELECTRIC DRILL
3/8" NUT DRIVER, ASSORTED CEDAR SHIMS,
ELECTRIC SCREW GUN W/ADJUSTABLE TORQUE
WONDER BAR, #2 & #3 PHILLIPS BITS
RIVET GUN & 5/16, 3/8 AND 7/16" HEX DRIVES

401 Jim Moran Blvd., PO Box 9601, Deerfield Beach, FL 33442
Tel (954) 429-9155 Fax (954) 428-3843

REVISIONS

NO.	DATE	BY
1.	07/18/00	TEB
2.	11/19/02	RJV
3.	11-11-03	JMH
4.		

INSTALLATION DETAILS FOR
WELDED LOCKERS

DRWN BY	TEB	DATE	02/19/01	SCALE	NONE
CHK'D	MDS	DATE	02/19/01	DRWG NO.	SB-2301-2
APP'D		DATE			